



LMX

Dry-Running, Unpressurized Seal for Mixers and Agitators



These instructions must be read prior to installing, operating, and maintaining this equipment.

1 Equipment Check

- 1.1 **Follow plant safety regulations** prior to equipment disassembly:
 - 1.1.1 **Consult** the plant Material Safety Data Sheet (MSDS) files for hazardous material regulation.
 - 1.1.2 **Wear** designated personal safety equipment
 - 1.1.3 **Lock out** the mixer or agitator motor and valves to and from the vessel
 - 1.1.4 **Relieve** the pressure in the vessel
 - 1.1.5 Use plant **vessel entry procedures** if it is necessary to enter the vessel
- 1.2 **Secure the mixer or agitator shaft** in accordance with the mixer or agitator manufacturer's instructions.
- 1.3 **Remove the coupling and/or drive** to access the seal area. Follow the manufacturer's instructions.
- 1.4 **Remove the existing seal assembly.**
- 1.5 **Remove all burrs and sharp edges** from the shaft and vessel flange area. The shaft and vessel flange must be free of burrs, sharp edges, cuts, dents, or corrosion that might cause leakage past the sleeve packing O-rings and the gland gasket O-ring.
- 1.6 **Check requirements** for the shaft and the vessel flange. They must agree with the Dimensions shown in Figure 1.
- 1.7 **Check the assembly drawing** accompanying the seal assembly for specific seal design data, materials of construction, dimensions, and recommended piping connections.
- 1.8 **Check the shaft OD, vessel flange bolt size, bolt circle, and distance to the coupling or drive** to ensure that these dimensions agree with the seal assembly drawing provided.
- 1.9 **Handle the seal assembly with care**, it is manufactured to precise tolerances.

Figure 1: Mixer/ Agitator Shaft and Flange Requirements

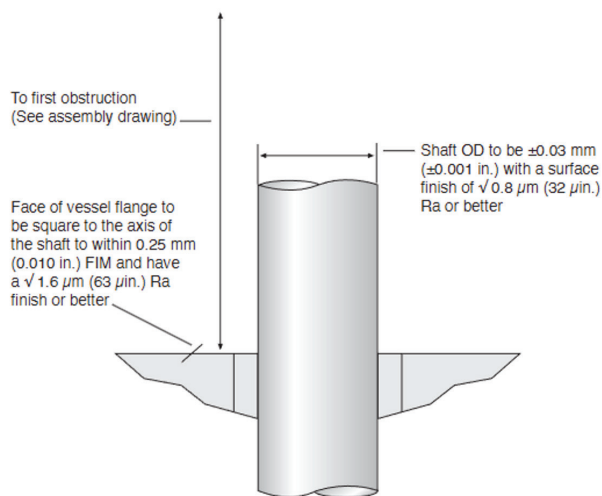

- Bearing, drive, and coupling must be in good condition.
- Maximum radial movement combined **shaft concentricity** and **shaft deflection** at face of vessel flange total = 0.120" (3.05mm) FIM
- Maximum **axial end play (vertical shaft movement): 0.100 in (2.54 mm) FIM**
- Do not assume individual maximum values are acceptable simultaneously.

2 LMX Seal Installation

Tools needed:

Tools provided:

- **Lubricant** for O-rings and equipment shaft OD.

Tools not provided:

- Wrenches to secure gland washer or bolts
- Allen wrenches for housing cap screws
- Allen wrenches for setting devices and set screws

- 2.1 **Lightly lubricate the equipment shaft** along then entire length the gasket O-rings will contact the shaft. Use the lubricant provided if it is compatible with the fluid process.
- 2.2 **Remove shipping plug** before installing the LMX onto the equipment shaft
- 2.3 **Install the LMX onto the equipment shaft** with the end containing the setting devices toward the equipment drive end and the position the seal assembly onto the vessel flange. Using the tapped holes for jacking to gently lower the canister assembly onto the vessel flange. Do not bolt the canister seal assembly to the vessel flange at this time. Care should be exercised when passing the seal sleeve incorporating the sleeve packing O-rings over any keyways or threads that may be present. Any steps or shoulders on the equipment shaft should be beveled to prevent damage (pinching and cutting) of these sleeve gasket O-rings during installation.
- 2.4 **Position the canister seal assembly** so that the Auxiliary Port is easily accessible.
- 2.5 **Reinstall the shaft coupling and/or drive. Remove any shaft holding or restraining clamps** and complete adjustments so that shaft is in its final operating position.
- 2.6 **Install and tighten the vessel flange studs or cap screws** to secure the canister seal assembly to the vessel flange. Do not overtighten.
- 2.7 **Tighten the set screws** in the sleeve drive collar uniformly with an Allen wrench.
- 2.8 **Remove the setting devices. Save the setting devices and attachment** hardware for future use.

3 Seal Operation

To ensure reliable operation of this sealing product, the following operating guidelines should be observed.

- 3.1 **Do not exceed the maximum vessel temperature** specified for the application. This could exceed the temperature limits of the seal materials of construction applied to the application.
- 3.2 **Do not exceed the seal material corrosion limits.** This seal was designed for the application shown on the seal assembly drawing. Do not exceed the limits of the material alloys and elastomers supplied in its construction.

For any problems encountered during installation and/or operation of this product, please contact your nearest Flowserve Sales and Service Representative or Authorized Distributor.

4 Repair

This product is a precision sealing device. The design and dimension tolerances are critical to seal performance. Only parts supplied by Flowserve should be used to repair a seal. To order replacement parts, refer to the part code and B/M number. A spare backup seal should be stocked to reduce repair time.

When seals are returned to Flowserve for repair, decontaminate the seal assembly and include an order marked **“Repair or Replace.” A signed certificate of decontamination** must be attached.

A Safety Data Sheet (SDS) must be enclosed for any product that came in contact with the seal. The seal assembly will be inspected and, if repairable, it will be rebuilt, tested, and returned.



Headquarters

Flowserve Corporation
5215 North O'Connor Blvd.
Suite 700
Irving, Texas 75039-5421 USA

Flowserve Corporation has established industry leadership in the design and manufacture of its products. When properly selected, this Flowserve product is designed to perform its intended function safely during its useful life. However, the purchaser or user of Flowserve products should be aware that Flowserve products might be used in numerous applications under a wide variety of industrial service conditions. Although Flowserve can provide general guidelines, it cannot provide specific data and warnings for all possible applications. The purchaser/user must therefore assume the ultimate responsibility for the proper sizing and selection, installation, operation, and maintenance of Flowserve products. The purchaser/user should read and understand the Installation Instructions included with the product, and train its employees and contractors in the safe use of Flowserve products in connection with the specific application.

While the information and specifications contained in this literature are believed to be accurate, they are supplied for informative purposes only and should not be considered certified or as a guarantee of satisfactory results by reliance thereon. Nothing contained herein is to be construed as a warranty or guarantee, express or implied, regarding any matter with respect to this product. Because Flowserve is continually improving and upgrading its product design, the specifications, dimensions and information contained herein are subject to change without notice. Should any question arise concerning these provisions, the purchaser/user should contact Flowserve Corporation at any one of its worldwide operations or offices.

©2026 Flowserve Corporation. All rights reserved. This document contains registered and unregistered trademarks of Flowserve Corporation. Other company, product, or service names may be trademarks or service marks of their respective companies.

SSIOM003310-01 (EN/LTR) April 2026